

TouchWo® 21.5" Touch Monitor

Model : TD215A

Views & Dimensions

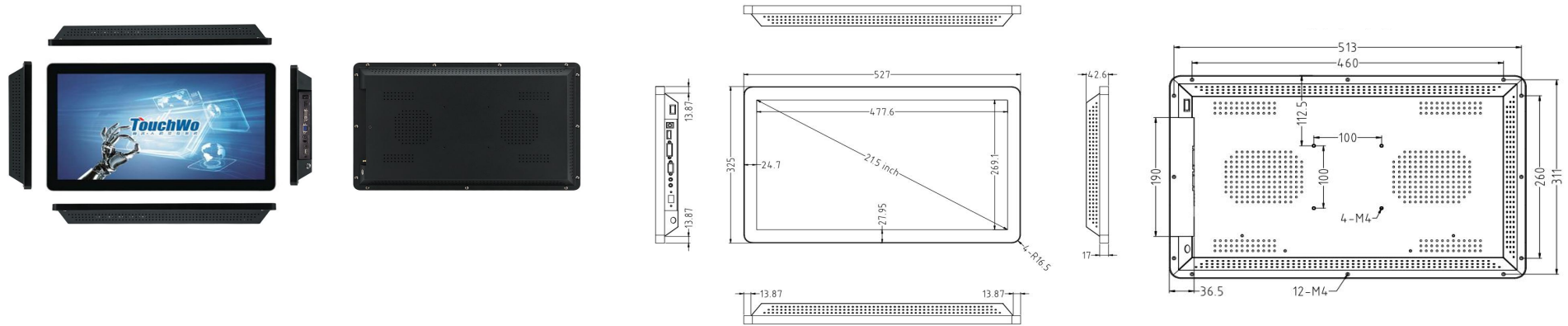

Features

- **24/7 Commercial Use**

Industrial-grade Power Supply

30,000-hour extended life LCD display

- **Wall mounted/desktop stand/embedded etc**

- **Stylish Appearance**

Industry-leading ultra-narrow screen bezel-24.7mm

17mm full aluminum alloy frame

- **Surface IP65 waterproof**

CE FC RoHS

Tech Specs

LCD Panel	Screen diagonal	21.5inch	Touch Panel	Touch technology	PCAP
	Physical resolution	1920*1080		Response time	<5ms
	Aspect ratio	16:9		Touch points	10 points standard
	Display active screen size (mm)	477.6*269.1		Touch effective recognition	>1.5mm
	Colours displayed	16.7M		Scanning Frequency	200Hz
	Brightness (cd/m2)	250		Scanning accuracy	4096 * 4096
	Contrast	3000:1		Working Current/Voltage	180Ma/DC+5V±5%
	Visual Angle H/V (°)	89/89/89/89		Surface Hardness	Mohs class 7 explosion-proof glass
	Backlight Lifetime (hours)	LED 30,000			
Refrash Rate	60 Hz				

Operation Environment	Operation Temperature	0°C-50°C	Dimension	Machine(cm)	52.7 (W) *32.5 (H) *4.26 (T)
	Operation Humidity	10% - 80%		Package(cm)	57 (W) * 44 (H) *14.5 (T)
	Storage Temperature	-.5°C-60°C		Net weight	6.59kg
	Storage Humidity	10% - 85%		Gross weight	8.67kg

Power supply parameters	Power Input	100-240V AC 50/60Hz	Included in the Delivery	Manual	* 1
	Power Output	DC 12V 5A		Wall mount bracket	* 1
	Standby power consumption	≤0.5W		HDMI/USB cable	* 1
	Overall power consumption	<20W		Power Adapter&cable	* 1

External Connectors

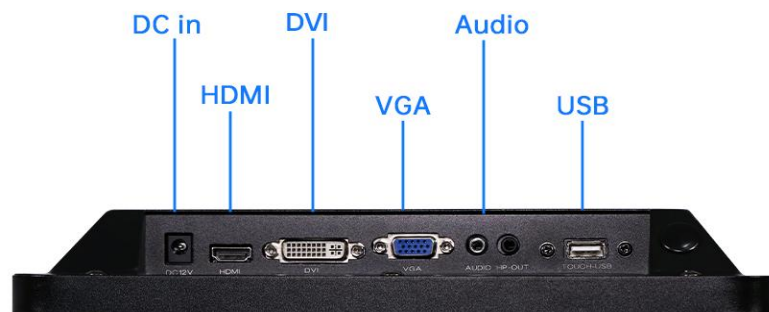

DC in	* 1	USB touch port	* 1	VGA	* 1
Power Socket	* 1	HDMI in	* 1	Audio in&out	* 1

Use Case

