

TouchWo®

10.1" Touch Pc

Model : DM101G

Views & Dimensions

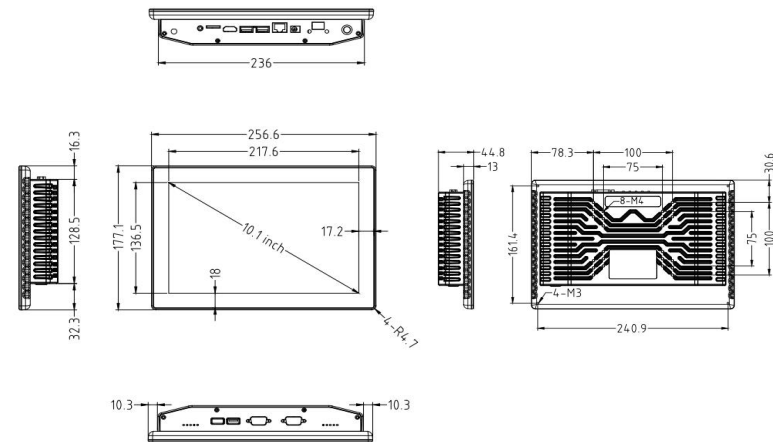

Features

- **24/7 Commercial Use**

Industrial-grade Power Supply

15,000-hour extended life LCD display

- **Support multiple installation requirements**

- **Stylish Appearance**

High precision die-casting integrated molding

High quality structural design of aluminum alloy

- **Surface IP65 waterproof**



Tech Specs

LCD Panel		Touch Panel	
Screen diagonal	10.1 inch	Touch technology	PCAP
Physical resolution	1280*800 / 1920*1200	Response time	<5ms
Aspect ratio	16 : 10	Touch points	10 points standard
Display size (mm)	217.6(W)*136.5(H)	Touch effective recognition	>1.5mm
Colours displayed	16.7M	Scanning Frequency	200Hz
Brightness (cd/m2)	≥250cd/m2	Scanning accuracy	4096 * 4096
Contrast	≥ 1000: 1	Working Current/Voltage	180Ma/DC+5V±5%
Visual Angle H/V (°)	85/85/85/85(Typ.) (CR≥10)	Surface Hardness	Mohs class 7 explosion-proof glass
Backlight Lifetime (hours)	15000h		
Refrash Rate	60 Hz		

Operation Environment		Dimension	
Operation Temperature	0°C-50°C	Machine(cm)	25.7(L) * 17.7(W) * 4.5(H)
Operation Humidity	10% - 80%	Package(cm)	49.5(L) * 37.2(W) * 9.5(H)
Storage Temperature	-5°C-60°C	Net weight	1.66 KG
Storage Humidity	10% - 85%	Gross weight	3.16KG
EMC	CE/FCC Class B	Mounting bracket	Desktop/Wall mounted

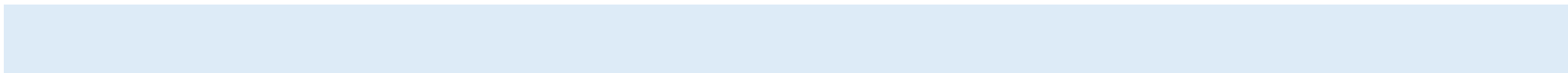

Android System	CPU	Rockchip RK3568	Rockchip RK3288	Rockchip RK3588
	Graphic GPU	ARM G52 2EE	Mali-T864	Mali-G610
	Memory	4G (4G optional)	2G (4G optional)	4G (8G optional)
	Storage	32G eMMC	16G/32G eMMC	64G/128G eMMC
	Network	10/100 RJ45, 802.11a/b/g/n/ac Wifi	100/1000M RJ45, 802.11a/b/g/n/ac Wifi	
	Pre-installed OS	Android 11	Android 9	Android 12

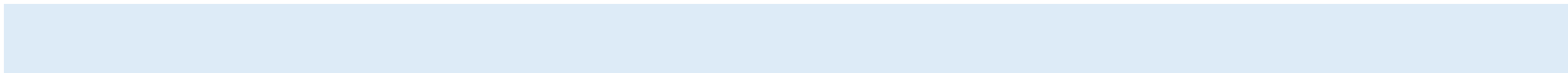

Power supply parameters	Power Output	DC 12V3A	Manual	* 1
	Standby power consumption	<20W	Mounting bracket	* 1
Vibration during work	SSD applied: 1.5 Grms, IEC 60068-2-64, random, 5 ~ 500 Hz, 1 hr/axis	Included in the Delivery	Power Adapter&cable	* 1
Impact during work	SSD applied: 10 G, IEC 60068-2-27, Half sine wave, lasting for 11ms		WiFi antenna	* 1

External Connectors



Network 1 * 10/100/1000Mbps controller/1 * wifi

USB 4 * USB (including OTG)

Serial port 2 * TTL/(optional RS-232/RS-485)

Power interface 1 * 2P Phoenix terminal interface/1 * DC2.1

HDMI 1 * HDMI 1.4

Audio 1 * Ear Mic 2-in-1

Use Case

