

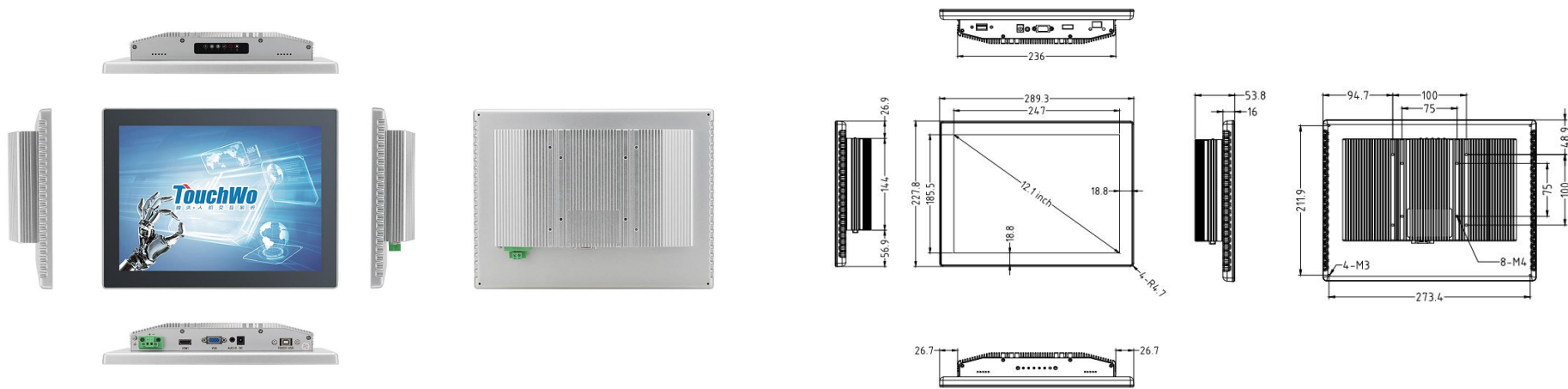

12.1" Industrial Touch Monitor

Model : DM121G

Views & Dimensions



Features

- **24/7 Commercial Use**

Industrial-grade Power Supply

15,000-hour extended life LCD display

- **Support multiple installation requirements**

- **Stylish Appearance**

High precision die-casting integrated molding

High quality structural design of aluminum alloy

- **Surface IP65 waterproof**



Tech Specs

LCD Panel		Touch Panel	
Screen diagonal	12.1 inch	Touch technology	PCAP
Physical resolution	1024*768	Response time	<5ms
Aspect ratio	4 : 3	Touch points	10 points standard
Display size (mm)	247(W)*185.5(H)	Touch effective recognition	>1.5mm
Colours displayed	16.7M, 72% NTSC	Scanning Frequency	200Hz
Brightness (cd/m2)	≥350cd/m2	Scanning accuracy	4096 * 4096
Contrast	≥ 1200: 1	Working Current/Voltage	180Ma/DC+5V±5%
Visual Angle H/V (°)	85/85/85/85(Typ.) (CR≥10)	Surface Hardness	Mohs class 7 explosion-proof glass
Backlight Lifetime (hours)	50000h		
Refrash Rate	60 Hz		

Operation Environment		Dimension	
Operation Temperature	0°C-50°C	Machine(cm)	28.9(L) * 22.8(W) * 5.4(H)
Operation Humidity	10% - 80%	Package(cm)	49.5(L) * 37.2(W) * 9.5(H)
Storage Temperature	-5°C-60°C	Net weight	2.51 KG
Storage Humidity	10% - 85%	Gross weight	3.89 KG
EMC	CE/FCC Class B	Mounting bracket	Desktop/Wall mounted

Power supply parameters	Power Output	DC 12V3A	Manual	* 1	
	Standby power consumption	<20W		Mounting bracket	* 1
Vibration during work	SSD applied: 1.5 Grms, IEC 60068-2-64, random, 5 ~ 500 Hz, 1 hr/axis		Included in the Delivery	Power Adapter&cable	* 1
Impact during work	SSD applied: 10 G, IEC 60068-2-27, Half sine wave, lasting for 11ms			USB-B cable	* 1

External Connectors

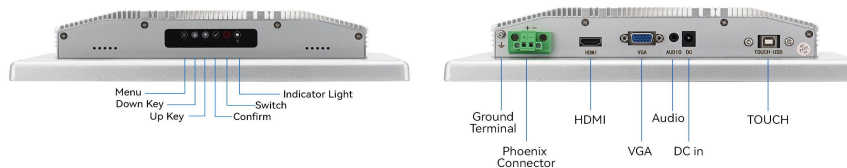

Button function	AUTO, MENU,POWER,LEFT,RIGHT	Touch interface	1 * TOUCH (B port)
Power interface	1 * 2P Phoenix terminal interface/1 * DC2.1	Video input	1 * HDMI 1.4/1 * VGA
Audio	1 * Audio Input		

Use Case

