

TouchWo® 21.5" Touch Monitor

Model : HD215

Views & Dimensions

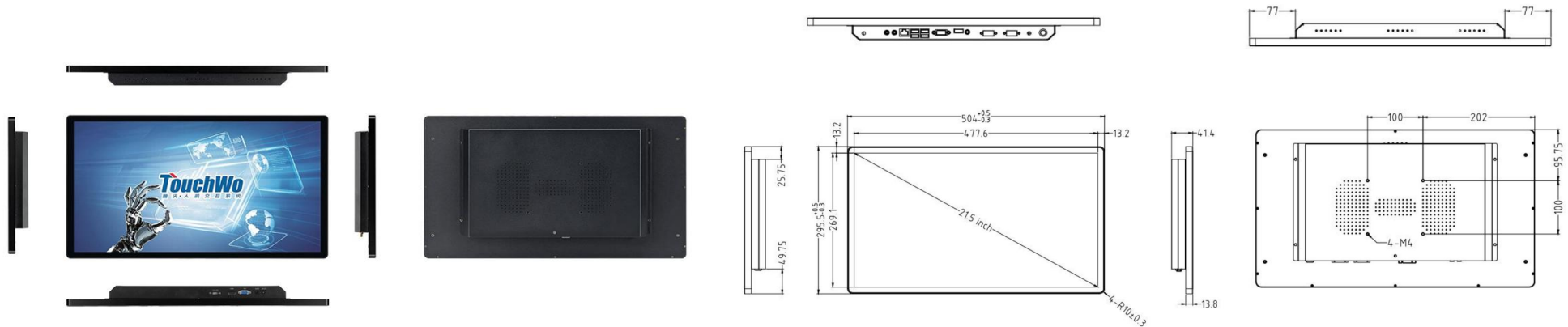

Features

- **24/7 Commercial Use**

Industrial-grade Power Supply

30,000-hour extended life LCD display

- **Wall mounted/desktop stand/embedded etc**

- **Stylish Appearance**

Industry-leading ultra-narrow screen bezel-13.2mm

13.8mm full aluminum alloy frame

- **Surface IP65 waterproof**



Tech Specs

LCD Panel		Touch Panel	
Screen diagonal	21.5inch	Touch technology	PCAP
Physical resolution	1920*1080	Response time	<5ms
Aspect ratio	16:09	Touch points	10 points standard
Display active screen size (mm)	477.6 * 269.1	Touch effective recognition	>1.5mm
Colours displayed	16.7M	Scanning Frequency	200Hz
Brightness (cd/m ²)	300	Scanning accuracy	4096 * 4096
Contrast	1000:1	Working Current/Voltage	180Ma/DC+5V±5%
Visual Angle H/V (°)	178/178	Surface Hardness	Mohs class 7 explosion-proof glass
Backlight Lifetime (hours)	LED 30,000		
Refresh Rate	60 Hz		

Operation Environment		Dimension	
Operation Temperature	0°C-50°C	Machine(cm)	50.4 (W) * 29.6 (H) *4.15 (T)
Operation Humidity	0% - 90%	Package(cm)	57 (W) * 44 (H) *15 (T)
Storage Temperature	0°C-60°C	Net weight	4.5kg
Storage Humidity	0% - 65%	Gross weight	6.12kg

Power supply parameters	Power Input	110-240V AC 50/60Hz	Included in the Delivery	Manual	* 1
	Power Output	DC 12V3A		Wall mount bracket	* 1
	Standby power consumption	≤0.5W		HDMI & USB cable	* 1
	Overall power consumption	<20W		Power Adapter&cable	* 1

External Connectors

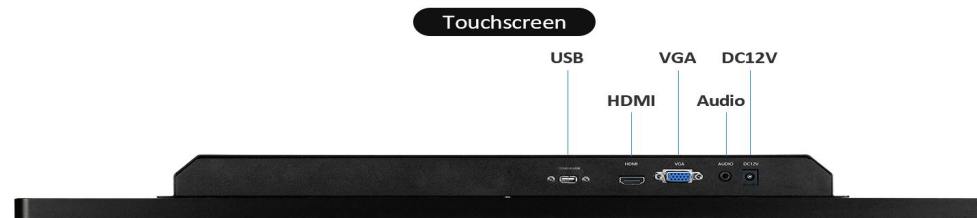

Audio in&out	* 1	USB	* 1	VGA	* 1
Power Socket	* 1	HDMI out	* 1		

Use Case

