

# 23.8" Self Service Touch Kiosk(ARM)



**TouchWo Smart Manufacturing: Illuminating the Future**

- **24/7 Commercial Use**  
Industrial-grade Power Supply  
30,000-hour extended life LCD display
- **Free Customization**  
Multiple peripheral configurations available  
Integrate your own POS terminal
- **Monitor/Android / Windows Optional**  
Android 11 default, High-end spec optional  
Latest Celeron J6412 default  
i3 i5 i7 Optional
- **Easy Desk Mount, Wall Mount or Floor Mount**  
VESA holes for wall mount  
Optional with desktop stand or floor stand

## Android System

CPU	Rockchip RK3568	Rockchip RK3588	Rockchip RK3576
Graphic GPU	ARM G52 2EE	Mali-G610	Arm Mali-G52
Memory	2G (4G optional)	4G (8G optional)	4G (8G optional)
Storage	16G/32G eMMC	64G/128G eMMC	32G/64G eMMC
Network	10/100M RJ45, 802.11 a/b/g/n/ac Wifi	100/1000M RJ45, 802.11 a/b/g/n/ac Wifi	100/1000M RJ45, 802.11 a/b/g/n/ac Wifi
Pre-installed OS	Android 11	Android 12	Android 14

## LCD Panel

Screen diagonal	23.8 inch
Display active screen size (mm)	529 * 298.5 mm
Aspect ratio	16:9
Physical resolution	1080*1920
Colours displayed	16.7M
Brightness (cd/m <sup>2</sup> )	≥250
Contrast	1000:1
Visual Angle H/V (°)	178/178
Backlight Lifetime (hours)	LED 30,000
Refresh Rate	60 Hz

## Touch Panel

Touch technology	PCAP
Response time	<5ms
Touch points	10 points standard
Touch effective recognition	>1.5mm
Scanning Frequency	200Hz
Scanning accuracy	4096×4096
Working Current/Voltage	180Ma/DC+5V±5%
Surface Hardness	Mohs class 7 explosion-proof glass

## Operation Environment

Operation Temperature	0℃-50℃
Operation Humidity	10% - 80%
Storage Temperature	-5℃-60℃
Storage Humidity	10% - 85%

## Dimension

Machine(mm)	873 (W) × 370 (H) × 157 (T) mm
Package(mm)	970 (W) × 475 (H) × 250 (T) mm
Net weight	23.85 KG
Gross weight	26.40 KG

## Power supply parameters

Power Input	110-240V AC 50/60Hz
Power Output	DC 12V4A
Standby power consumption	≤0.5W
Overall power consumption	<60W

## External Connectors

RJ45 Ports	x1
Power Socket	x1
HDMI out	x1
USB	x4

## Included in the Delivery

Manual	x1
WiFi antenna	x1
Wall mount bracket	x1
AC Power cable	x1

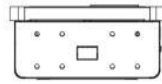

正视图

侧视图

背视图

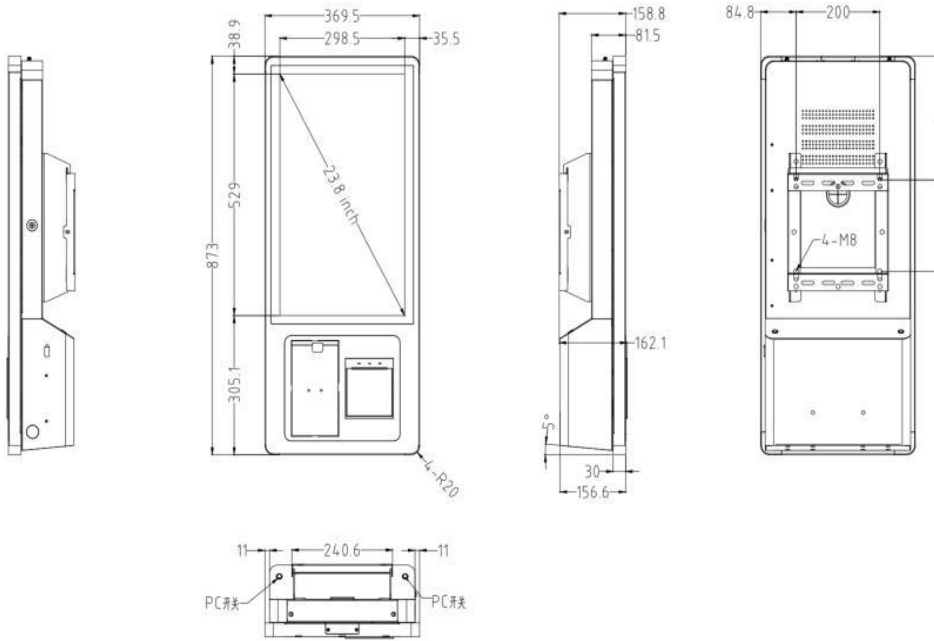

## Use Case

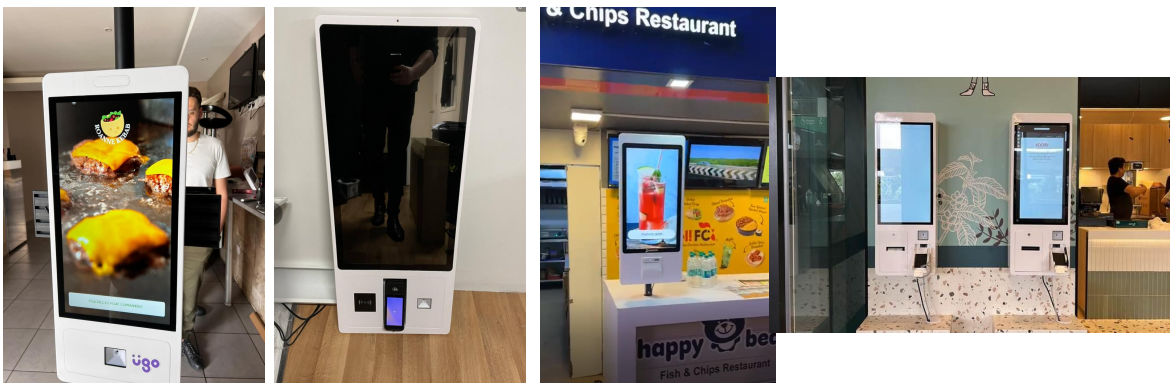

## Peripherals

The GD27D2 Kiosk comes equipped with a high-speed thermal printer, a QR code scanner, and an POS hole. Its versatile design allows for compatibility with a wide range of peripherals, and the option to customize with or without specific devices. With a short customization period ranging from 7 to 35 days, delivery can be completed efficiently.



### Thermal Printer

Model Epson TM-m30II / MS-E80I  
Printing Speed 250MM/S(MAX)  
Printing Width 72MM  
Paper Width 80MM(MAX)  
Resolution 203 dpi  
Paper Roll Dia 80MM(MAX)  
Paper Cut Auto Cut



### Barcode Scanner

Model EMT8020  
Resolution 640\*480 COMS  
Recognition Accuracy 5mil  
Field of View Horizontal 68°, Vertical 51°  
2D Codes PDF417, QR Code, DataMatrix, etc  
1D Codes Code 128, EAN-13, EAN-8, Code 39, etc



### RFID card reader

Model M11  
Frequency: IC Mifare1/; CPU/TypeA; 14443A  
Protocols: IC/ID  
Supported Ca 80MM(MAX)  
Functions: Read/Write IC cards, Read ID cards

### More Options for customization



Fingerprint Sensor



Metal Keyboard



Card Dispenser



Payment terminal



Camera



NFC-Payment



4G LTE



Battery-UPS

[Six-view Drawing](#)



[Installation](#)



**Wall mount bracket**

**Floor stand**



**Floor stand**

**Desk stand**